

CR1500-xxP-yyF-zzzS

**PV SOURCE CIRCUIT
COMBINERS**

User's Manual

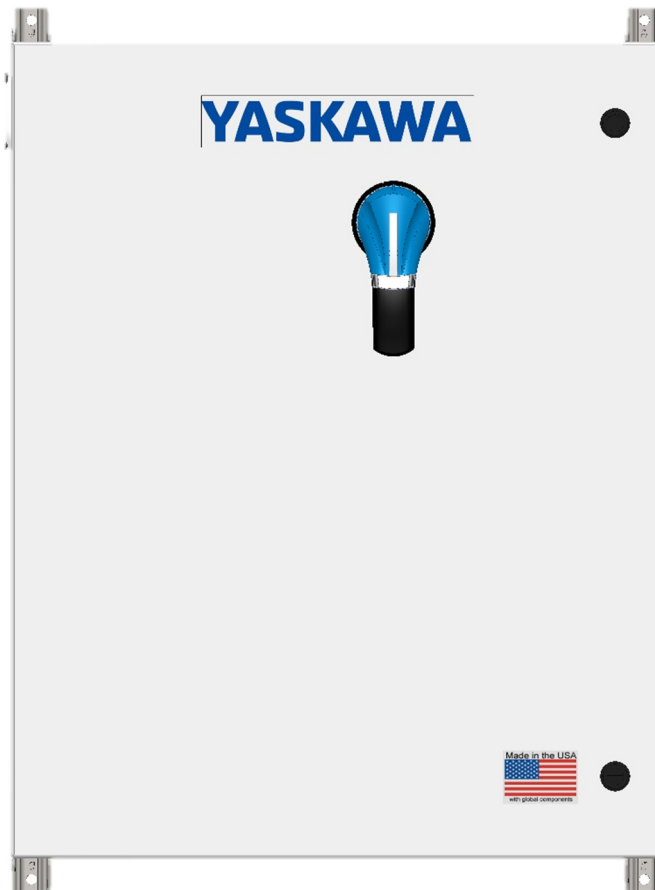

CONTENTS

1. IMPORTANT SAFETY INSTRUCTIONS	3
2. PRODUCT OVERVIEW	4
3. RATINGS AND SPECIFICATIONS	7
3.1 Models and Model Numbers	8
4. INSTALLATION	9
4.1 Unpacking and Inspection	9
4.1.1 Check for Damage	9
4.1.2 Remove Packing Material Inside the Combiner	9
4.2 Mounting	9
4.3 Wiring	11
5. OPERATION	18
6. WARRANTY & RMA INSTRUCTIONS	19
7. APPENDICES	19

FIGURES

2.1	Illustrated Usage of the CR1500-xxP-yyF-xxxS Combiner with the SOLECTRIA XGI 1500 Inverter
2.2	The CR1500-xxP-yyF-250S Combiner
2.3	The CR1500-xxP-yyF-400S Combiner
2.4	Schematic of the CR1500-xxP-yyF-400S Combiner
4.1	CR1500-xxP-yyF-zzzS Combiner front view (left) and side view (right), dimensions and mounting tab locations
4.2	CR1500-xxP-yyF-zzzS Combiner example mounting to struts
4.3	Bottom of the CR1500-xxP-yyF-zzzS Enclosure
4.4	PV Output Circuit Stud Plates (side view, left; top view, right)
4.5	Compression Lug Connections, Single and Dual Conductors
4.6	Stud Plate Elevation View
4.7	PV Source Circuit Equipment Ground Terminals
4.8	PV Output Circuit Equipment Ground Terminal
5.1	Switch Handle Positions for OFF (left) and ON (right)

TABLES

3.1	CR1500-xxP-yyF-zzzS Combiner Ratings and Specifications
3.2	CR1500-xxP-yyF-250S Combiner Model Numbers
3.3	CR1500-xxP-yyF-400S Combiner Model Numbers
4.1	Fuseholder Specifications
4.2	Example 1500VDC Replacement PV Fuse
4.3	PV Output Circuit Terminal Specifications
4.4	Compression Lug Specifications

1. IMPORTANT SAFETY INSTRUCTIONS

SAVE THESE INSTRUCTIONS

The **SOLECTRIA® Remote PV Combiners with Output Fuse** (CR1500-xxP-yyF-zzzS) are compatible with, and intended for use with, PV Arrays connected to **SOLECTRIA XGI 1500 Inverters**. The Combiners come in two model series:

- **CR1500-xxP-yyS-250F**, with a 250A rated disconnect switch and 315A output circuit fuse, for the XGI 1500-166 series inverters
- **CR1500-xxP-yyS-400F**, with a 400A rated disconnect switch and 450A output circuit fuse, for the XGI 1500-250 series inverters, and the XGI 1500-166 series inverters when large output conductors are desired to minimize voltage drop and loss.

Before using a CR1500-xxP-yyF-zzzS Combiner, please read all instructions and caution markings in this manual and on the Combiner, as well as all other instructions and warnings for associated equipment.

This manual contains important instructions that must be followed during installation and operation of the CR1500-xxP-yyF-zzzS Combiner. To reduce the risk of electrical shock and to ensure the safe installation and operation of the Combiner, the following safety symbols are used to indicate dangerous conditions and important safety instructions.



WARNING
Could Injure
Personnel or
Damage Equipment



Instructions
for Qualified
Personnel Only



Positive
Connection
Point Symbol



Negative
Connection
Point Symbol



Ground
Connection
Point Symbol



DC Electrical
Connection
Point Symbol



WARNING: Disconnect all PV modules before wiring. PV arrays produce dc voltage when exposed to light and could create a hazardous condition. Always verify the absence of voltage before performing work on the CR1500-xxP-yyF-zzzS Combiner.



WARNING: Connecting PV Source Circuits to the input of the Combiner and connecting the PV Output Circuit to the XGI 1500 inverter, must only be done after receiving approval from the utility company and Authority Having Jurisdiction (AHJ), and should only be performed by qualified persons.



WARNING: The CR1500-xxP-yyF-zzzS Combiners are intended for use with the **SOLECTRIA XGI 1500 Inverters**.

2. PRODUCT OVERVIEW

The primary function of the CR1500-xxP-yyF-zzzS Combiners is to combine PV Source Circuits from a PV array in parallel, safely, and form a resulting PV Output Circuit *with overcurrent protection*, and ready for connection to downstream equipment. Note that the presence of the PV Output Circuit fuse in the CR1500-xxP-yyF-zzzS Combiner allows users to take full advantage of NEC Article 690.8(A)(2) to calculate the Maximum Circuit Current and size the PV Output Circuit conductors.

2020 National Electrical Code Article 690.8(A)(2)

Circuits Connected to the Input of Electronic Power Converters

Where a circuit is protected with an overcurrent device not exceeding the conductor ampacity, the maximum current shall be permitted to be the rated input current of the electronic power converter input to which it is connected.

The CR1500-xxP-yyF-zzzS Combiners are intended for use with the **SOLECTRIA XGI 1500 Inverters**. Refer to the illustration in Figure 2.1 showing the CR1500-xxP-yyF-zzzS Combiner's general usage in a system with the **SOLECTRIA XGI 1500 Inverter**.

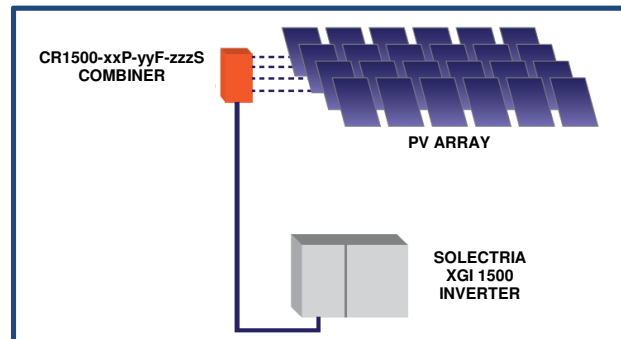

Figure 2.1 – Illustrated Usage of the CR1500-xxP-yyF-zzzS Combiner with the SOLECTRIA XGI 1500 Inverter

The CR1500-xxP-yyF-zzzS Combiners (see Fig 2.2 – 2.4) perform the following functions:

(1) **PV Source Circuit Connections:**

- Touch-safe fuseholders with terminals for 16, 20, 24 or 28 positive-polarity PV Source Circuit conductors (depending upon model).
- Overcurrent protection provided by 20, 25, 30 or 32A fuses (depending upon model), factory installed for all positive-polarity PV Source Circuit conductors
- A 30-position bus for the negative-polarity PV Source Circuit conductors.
- Connection from all PV Source Circuit conductors to the internal DC bus.

(2) **DC Disconnect Switch:**

- DC disconnect switch, two-pole -- either 250A or 400A rated, depending upon model series -- fully integrated and externally operable; separates the combined PV Source Circuits from the PV Output Circuit terminals, overcurrent protection and conductors.

(3) **PV Output Circuit Connections:**

- Terminals accommodate a single 600kcmil conductor, or dual 600kcmil conductors per pole (250A and 400A model), for the field-installed PV Output Circuit conductors.
- Type II surge protection, factory installed.

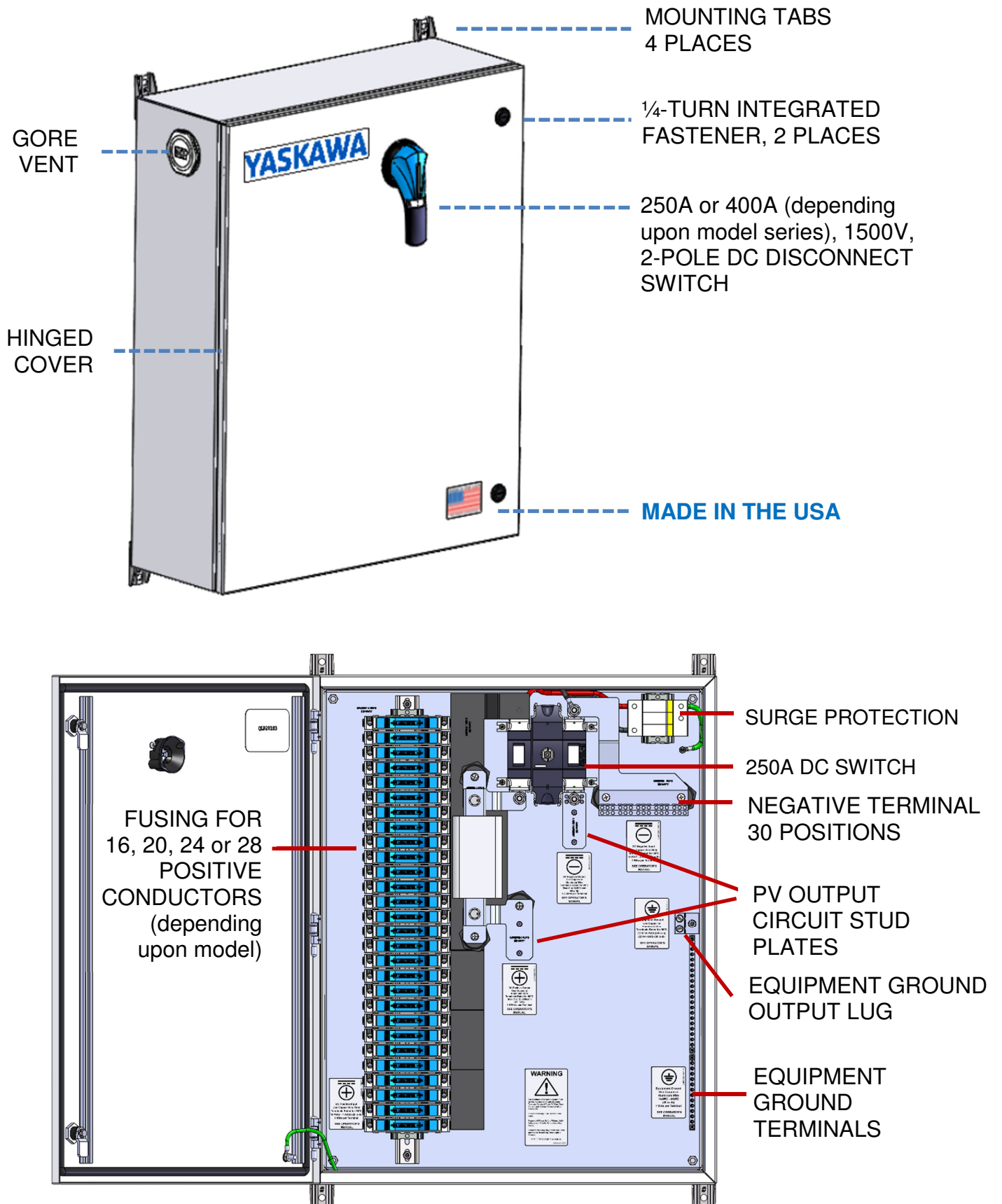

Figure 2.2 - The CR1500-xxP-yyF-250S Combiner

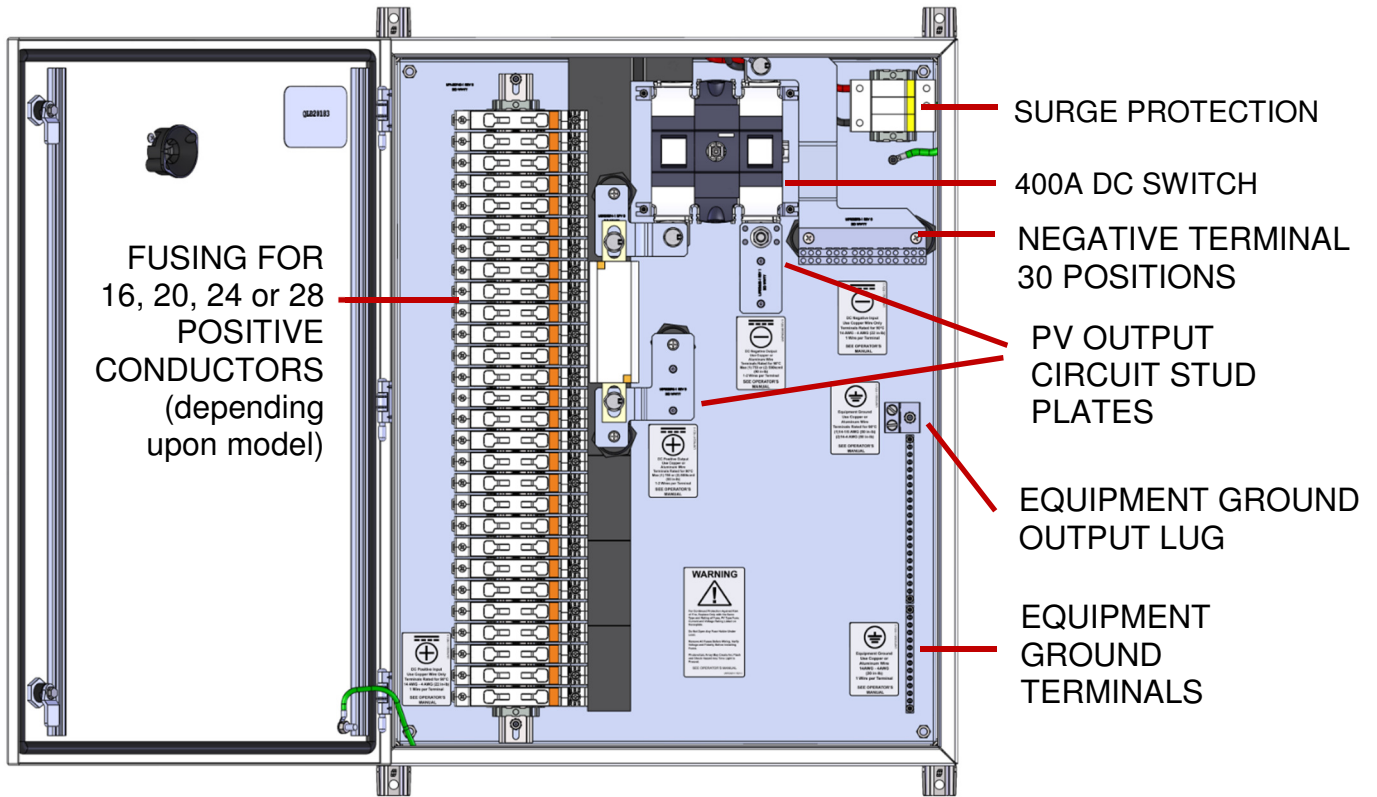

Figure 2.3 - The CR150-xxP-yyF-400S Combiner

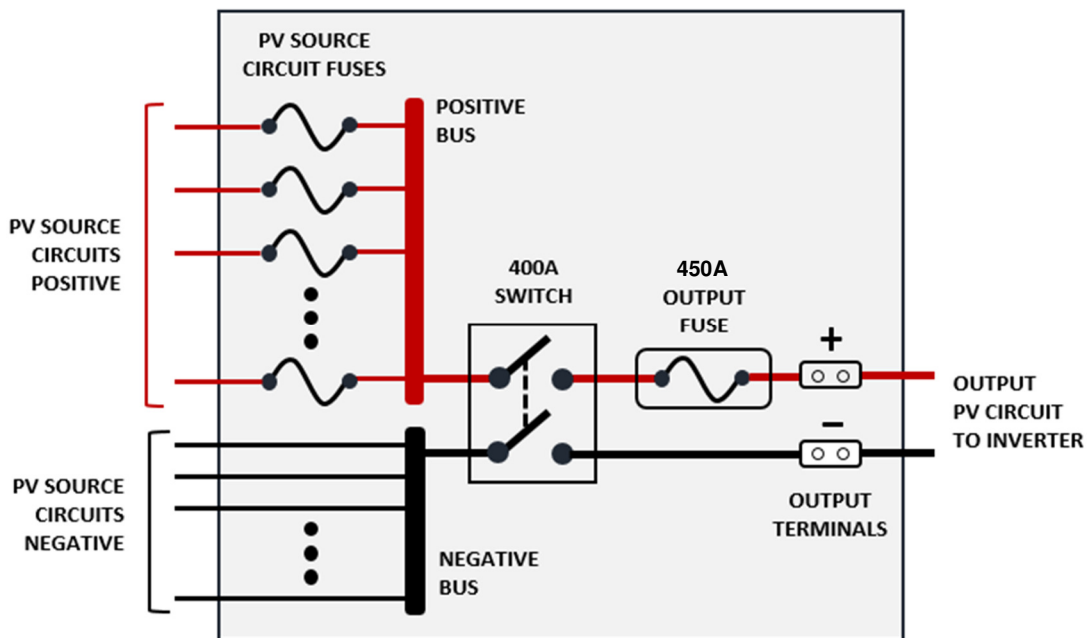

Figure 2.4 – Schematic of the CR150-xxP-yyF-400S Combiner (Note: the CR150-xxP-yyF-250S Combiner is similar, but with a 250A switch and 315A output fuse.)

3. RATINGS AND SPECIFICATIONS

CR1500-xxP-yyF-zzzS COMBINERS SPECIFICATIONS		
PV SOURCE CIRCUIT CONNECTIONS	CR1500-xxP-yyF-250S	CR1500-xxP-yyF-400S
Maximum Voltage	1500VDC	1500VDC
Fuseholder		
Wire Compatibility	14 – 6AWG, PV-Rated, Copper Wire Only	14 – 6AWG, PV-Rated, Copper Wire Only
Required Torque	22 in-lb (2.5 N-m)	22 in-lb (2.5 N-m)
Temperature Rating	-40C to +125C	-40C to +125C
Other	Touch-safe, lock-out/tag-out feature	Touch-safe, lock-out/tag-out feature
Fuse		
Rating	Options: 20A, 25A, 30A, 32A 1500VDC, factory installed	Options: 20A, 25A, 30A, 32A 1500VDC, factory installed
Type	Replace only with approved 1500VDC photovoltaic fuse, see Table 4.2	Replace only with approved 1500VDC photovoltaic fuse, see Table 4.2
Number of Fuse Positions	16, 20, 24 and 28 Positions	16, 20, 24 and 28 Positions
Fuse Configuration	Fusing for Positive Polarity Only	Fusing for Positive Polarity Only
DC DISCONNECT SWITCH		
Configuration	2-pole, 250A, 1500VDC, externally operable	2-pole, 400A, 1500VDC, externally operable
Maximum Continuous DC Current	200A	320A
PV OUTPUT CIRCUIT CONNECTIONS		
Maximum Voltage	1500VDC	1500VDC
Maximum Wire Size Compatibility	Cu or Al: 1 or 2 cond, 600 kcmil EGC: 14 AWG – 2/0 AWG	Cu or Al: 1 or 2 cond, 600 kcmil EGC: 14 AWG – 2/0 AWG
MECHANICAL, ENVIRONMENTAL, SAFETY		
Enclosure Dimensions (not including mounting tabs, see Fig. 4.1)	Height: 30.0 in (762mm) Width: 24.0 in (610mm) Depth: 8.00 in (203mm)	Height: 30.0 in (762mm) Width: 24.0 in (610mm) Depth: 8.00 in (203mm)
Enclosure Material & Rating	Polyester Powder-Coated Steel, Type 4	Polyester Powder-Coated Steel, Type 4
Weight	85 lbs	85 lbs
Ambient Temperature Range	-40°F to 140°F (-40°C to +60°C)	-40°F to 140°F (-40°C to +60°C)
Surge Protection	Type 2, +/-GND, Common Mode & Differential Mode	Type 2, +/-GND, Common Mode & Differential Mode
Safety Certification & Listing / Certification Agency	TUV, UL1741	TUV, UL1741
Standard Warranty	5 Years standard	5 Years standard

Table 3.1 – CR1500-xxP-yyF-zzzS Combiner Ratings and Specifications

3.1 Models and Model Numbers

The CR1500-xxP-yyF-zzzS Combiners are available in two model series, and with multiple configurations for 16 to 28 input PV Source Circuits. The model numbers for the CR1500-xxP-yyF-zzzS Combiners are defined in Tables 3.2. and 3.3.

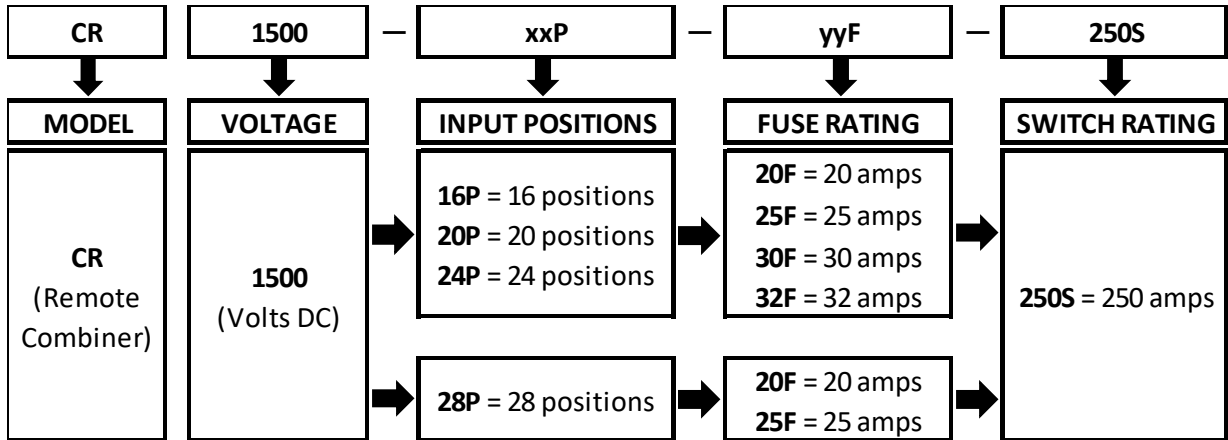

Table 3.2 Combiner models with 250A switch

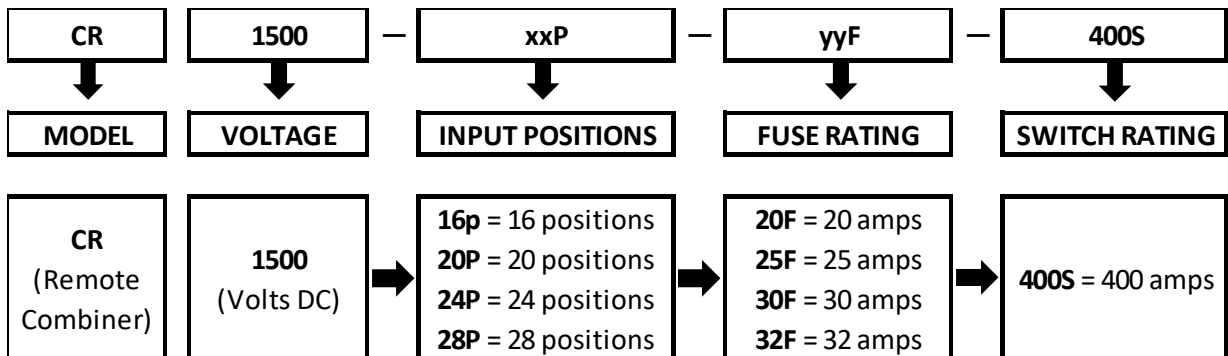

Table 3.3 Combiner models with 400A switch

4. INSTALLATION

The steps for successful installation of the CR1500-xxP-yyF-zzzS Combiners are:

- (1) Unpacking and Inspection
- (2) Mounting
- (3) Conduit and Fittings
- (4) Wiring and Conductor Installation
- (5) Testing and Commissioning

4.1 Unpacking and Inspection

4.1.1 Check for Damage

Yaskawa Solectria Solar thoroughly inspects and tests each CR1500-xxP-yyF-zzzS Combiner before it is shipped. Even though the Combiners are delivered in rugged packaging, damage could occur to the Combiners during shipment.

- ✓ Inspect the Combiner after removing it from its packaging. Take care not to set the Combiner on gravel or other surface that could scratch the paint.
- ✓ If damage is observed, take digital photos to document the damage and immediately report the damage to the shipping company.
- ✓ If the recipient has any question about the potential shipping damage, contact Yaskawa Solectria Solar (see Section 6 for contact information).
- ✓ If Yaskawa Solectria Solar determines that the Combiner must be returned, obtain an RMA number from Yaskawa Solectria Solar and instructions for returning the unit.

4.1.2 Remove Packing Material Inside the Combiner

Remove and properly dispose of all cardboard, tape and other packing material that may be inside the Combiner enclosure.

4.2 Mounting

The Combiner is designed to mount in any convenient location. Typically, the CR1500-xxP-yyF-zzzS Combiner will be mounted near the PV array, close to the input PV Source Circuits and some distance from the XGI 1500 inverter. The CR1500-xxP-yyF-zzzS Combiner is equipped with four integrated mounting tabs (see Fig. 4.1) to facilitate attachment to a variety of surfaces. The CR1500-xxP-yyF-zzzS enclosure is rated Type 4 and will maintain this rating when the user follows appropriate installation methods.

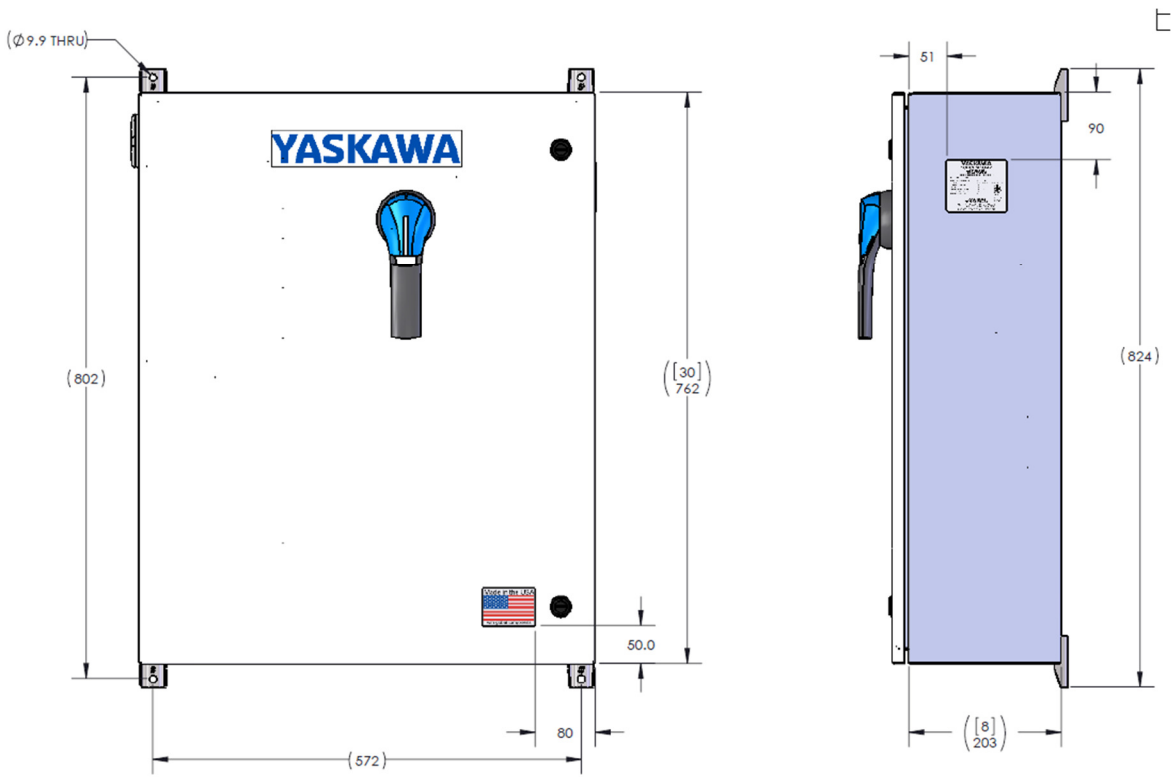

Figure 4.1 - CR1500-xxP-yyF-zzzS Combiner front view (left) and side view (right), dimensions and mounting tab

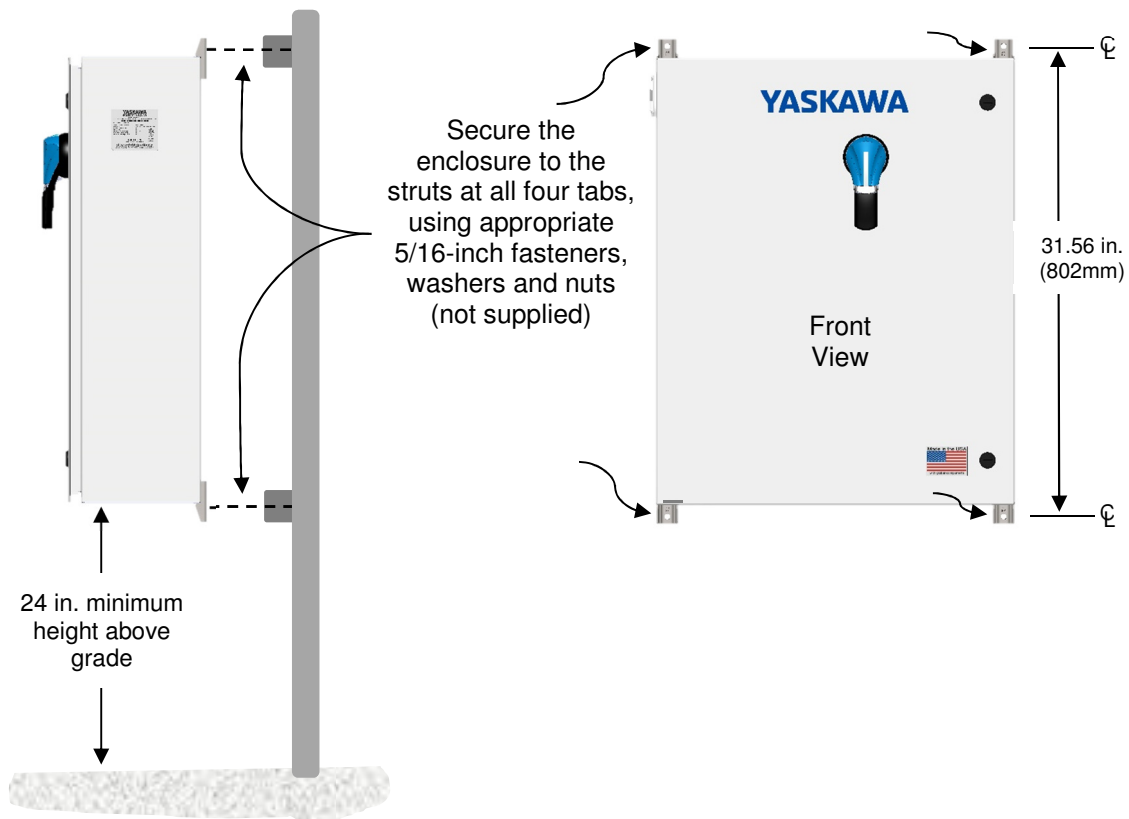

Figure 4.2 - CR1500-xxP-yyF-zzzS Combiner example mounting to struts

4.3 Wiring

Completing the installation of the CR1500-xxP-yyF-zzzS Combiner requires:

- (1) field wiring of the PV Source Circuits (up to 28) -- positive polarity conductors to the fuseholders, negative polarity conductors to the 30-position negative terminal block, and equipment ground wires to the equipment ground terminals, and
- (2) field wiring of conductors from the PV Output Circuit terminals and the equipment ground lug to the XGI 1500 inverter (see the XGI 1500 User's Manual for further details on those connections).

STEP 1: Confirm That No Wiring is Connected to the Combiner

- ✓ This is the first step of the installation and no wiring should be present into or out of the CR1500-xxP-yyF-zzzS Combiner. No input PV Source Circuits conductors should be present, and no PV Output Circuit conductors should be present.
- ✓ If the XGI 1500 inverter is in place, confirm that the disconnect switch is in the OFF position (even though the wiring between the CR1500-xxP-yyF-zzzS Combiner and the XGI 1500 inverter is not yet in place). The window on the disconnect switch body will show the "O" (Off) switch status.
- ✓ Remove fuses from all of the touch-safe fuseholders in the CR1500-xxP-yyF-zzzS. Store the fuses for later re-installation.

STEP 2: Prepare the Enclosure for Conduits

- ✓ Conduit and strain reliefs can be located anywhere suitable on the bottom face of the Combiner as shown in Figure 4.3.
- ✓ Add the necessary holes for the conduit and fittings. The Combiner provides adequate space for up to six 9-conductor strain reliefs, readily accommodating up to 28 pairs of conductors from 28 input PV Source Circuits, the maximum allowable.
- ✓ Remove all metal shavings and debris from the inside of the Combiner.



Remove all metal shavings and debris from the inside of the CR1500-xxP-yyF-zzzS enclosure.

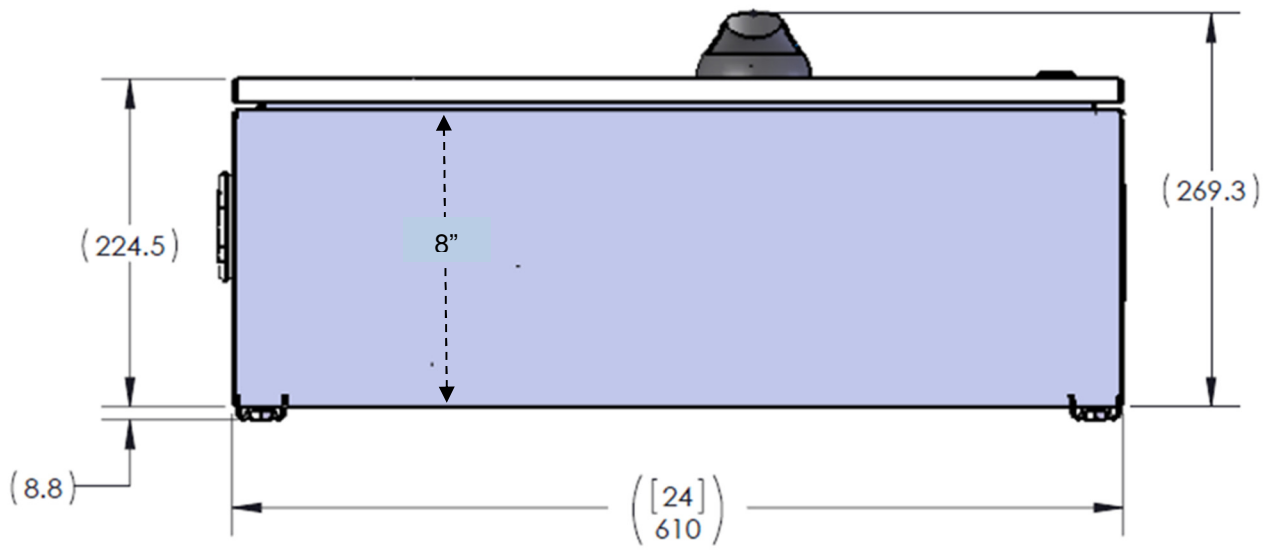

Fig 4.3 Bottom of the CR1500-xxP-yyF-zzzS Enclosure

Conduit Connections



Conduits connected to an outdoor enclosure can introduce water vapor into the enclosure and lead to the formation of condensation inside. Failure to follow these guidelines can result in water intrusion into the unit through the conduit connections and may void the warranty.

Follow these instructions and best practices when securing conduits to the Combiner.

1. Use UL514B certified water-tight conduit fittings and proper installation methods to provide a water-tight connection that will maintain the Type 4 rating of the enclosure.
2. Use an appropriately-rated sealant and seal the conduits fully to prevent the exchange of air between the conduit and the enclosure. Sealing the conduit will help prevent condensation in the enclosure.

STEP 3: PV Source Circuit Connections



Do not attempt to make connections to the CR1500-xxP-yyF-zzzS Combiner if not qualified for electrical work.

See NEC Articles 310 and 690 for proper PV Source Circuit conductor sizing. The rating of the fuseholders and the range of compatible conductor sizes are shown in Table 4.1.

FUSEHOLDER SPECIFICATIONS	
Wire Compatibility	14 AWG – 6 AWG stranded 14 AWG – 10 AWG solid 90°C Copper Conductors Only
Voltage Rating	1500 VDC
Ampere Range	Up to 32A
Torque Setting	22 in-lb, #2 Phillips

Table 4.1 - Fuseholder Specifications

- ✓ Verify the absence of voltage in the PV Source Circuit conductors.
- ✓ Run the PV Source Circuit conductors into the Combiner either through conduit or strain-relief connectors.
- ✓ Connect the positive conductors to the touch-safe fuseholders, one conductor per fuseholder.
- ✓ Connect the negative conductors to the negative polarity terminals (not fused).
- ✓ Connect equipment ground conductors to the equipment ground terminals.
- ✓ Torque each PV Source Circuit conductor to 22 in-lb with a #2 Phillips screwdriver.

Only replace the fuses in the CR1500-xxP-yyF-zzzS Combiner fuseholders with the approved 1500Vdc fuses in Table 4.2 below.

FUSE RATING	MANUFACTURER / MODEL		
	MERSEN	LITTELFUSE	EATON / BUSSMAN
15A	HP15M15	SPXV015	PV-15A10F85L
	HP15M15R		
20A	HP15M20	SPXVO20	PV-20A10F85L
	HP15M20R		
25A	HP15M25	SPXV025XM	PV-25A10F85L
	HP15M25R		
30A	HP15M30	SPXV030XM	PV-30A10F85L
	HP15M30R		
32A	HP15M32	SPXV032XM	NA
	HP15M32R		

Table 4.2 – Approved Replacement PV Fuses – Do Not Substitute

Negative PV Source Circuit conductors terminate on the 30-position terminal block, with the following specifications.

	<ul style="list-style-type: none"> • 30 position • 4 – 14 AWG • Copper and Aluminum • 90C Rating • Torque to 20 in-lb • Flat-head screwdriver
---	---

STEP 4: PV Output Circuit Connections

The CR1500-xxP-yyF-zzzS Combiner provides stud plates just below the DC disconnect switch body, with 8mm (5/16 in.) studs for customer-supplied compression lugs for both positive and negative PV Output Circuit conductors. See Fig. 4.4. The terminals are rated for 90°C. Refer to NEC Articles 310 and 690 for proper sizing of output circuit conductors. One and two lugs are allowed. Basic specifications are in Table 4.3.

Wire Terminal Temperature Rating	Number of Terminals	Number of Wires per Terminal Allowed	Max Conductor Size Allowed (Copper or Aluminum Conductors)
90°C	1 per pole	1 – 2	(1 or 2) 600 kcmil

Table 4.3 – PV Output Circuit Terminal Specifications

Compression lugs are NOT provided with the CR1500-xxP-yyF-zzzS Combiner. The lugs must conform to the specifications given in Table 4.4.

Lug Type	Stud Spacing	Plating	Max. Tongue Width
Two-hole	1.75 in	Tin Plated	1.95 in

Table 4.4 – Compression Lug Specifications

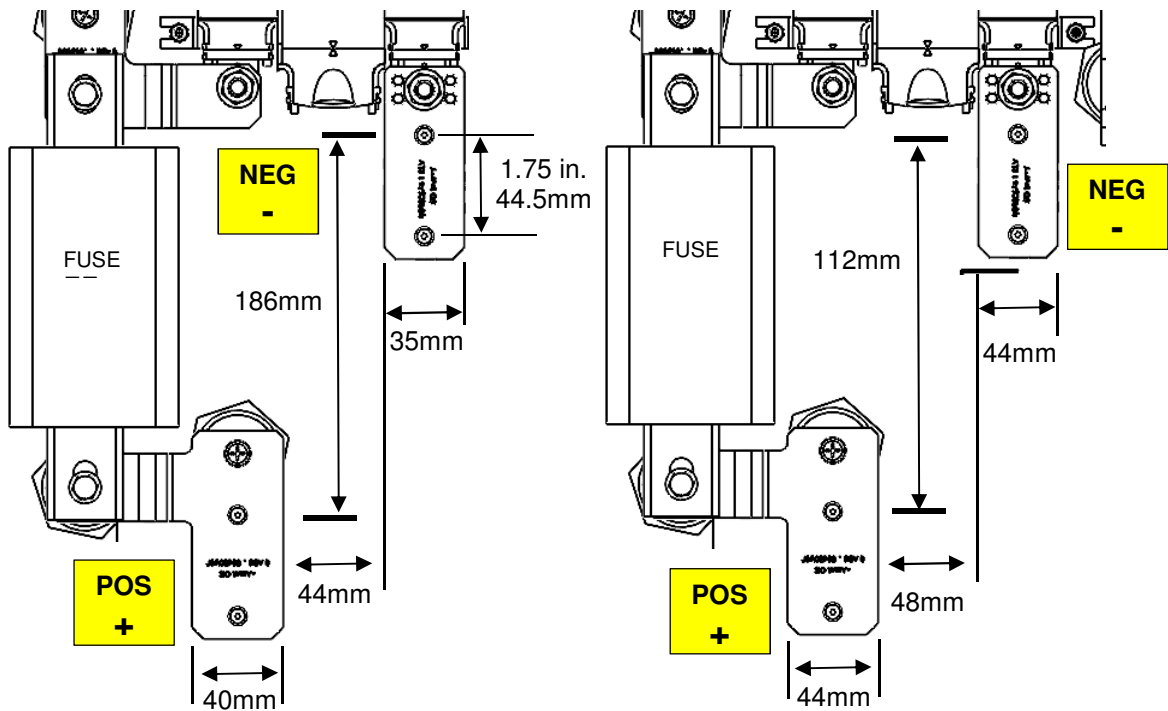

Figure 4.4 – PV Output Circuit Stud Plates CR1500-xxP-yyF-250S (left) and CR1500-xxP-yyF-400S (right)

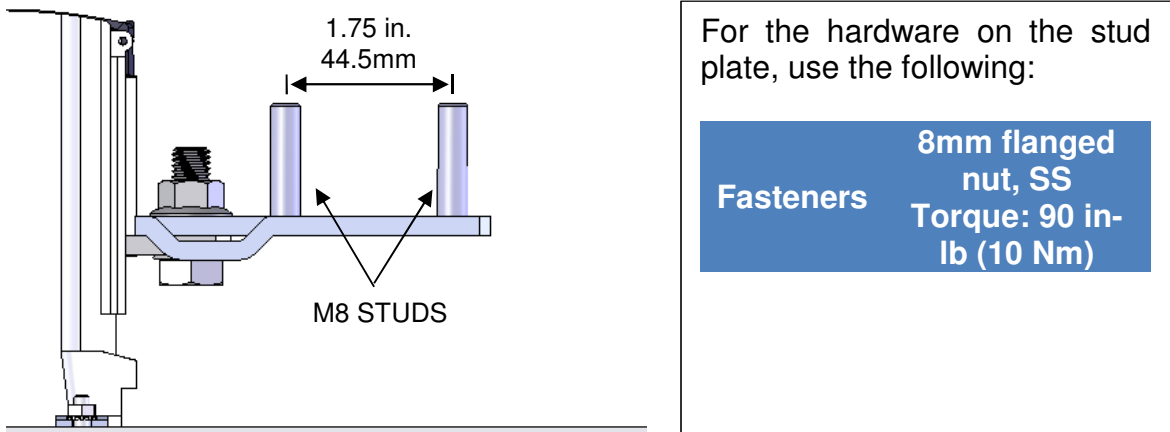

Figure 4.5 – Stud Plate Elevation View

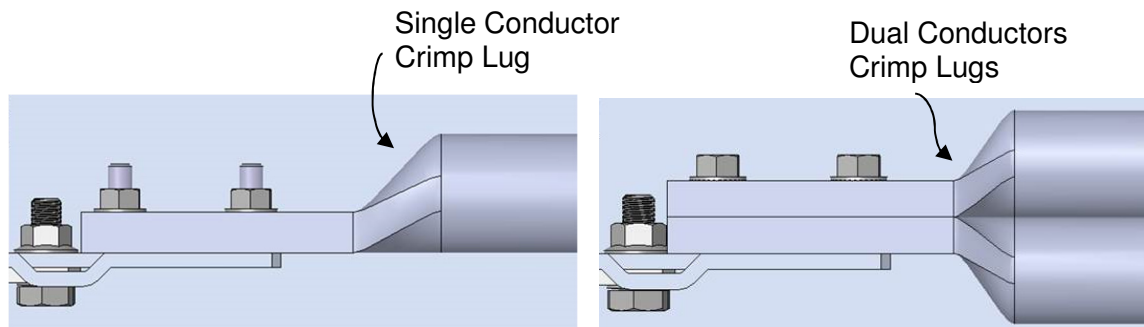

Figure 4.6 – Compression Lug Connections, Single and Dual Conductors

Aluminum Conductors



Aluminum oxidizes quickly when exposed to the atmosphere. An oxidized layer is a poor conductor that could lead to thermal issues, production loss, or damage to the Combiner.

When using aluminum conductors, follow these steps to prepare the conductors:

1. Prepare one wire at a time.
2. Remove the appropriate insulation from the wire.
3. Using a wire brush, remove the oxidized outer layer from the aluminum conductors.
4. Immediately apply a neutral dielectric grease, such as Ideal NOALOX® anti-oxidant compound, and connect the aluminum cable to the terminal.
5. If the connection is not made within 30 seconds of applying the compound, repeat this process, as an oxidized layer may have formed on the conductor.

STEP 5: Equipment Ground Wire Connections

Terminals are provided in the Combiner for all Equipment Grounding Conductors (EGCs) associated with the PV Source Circuits. Torque each EGC for the PV Source Circuits per the specifications in Fig 4.6.



	<ul style="list-style-type: none">• 20 position• 4 – 14 AWG• Copper and Aluminum• 90°C Rating• Torque to 20 in-lb• Flat-head screwdriver
	<ul style="list-style-type: none">• 12 position• 4 – 14 AWG• Copper and Aluminum• 90°C Rating• Torque to 20 in-lb• Flat-head screwdriver

Fig. 4.7 - PV Source Circuit Equipment Ground Terminals

The output Equipment Ground Conductor should be connected to the 2-position ground lug, with specs as in the specifications in Figure 4.7.

	<ul style="list-style-type: none"> • 2 position • (1) 14 – 2/0 AWG • (2) 14 – 1/0 AWG • Copper and Aluminum • 90°C Rating • Torque to 50 in-lb • 3/16 Allen Hex
---	--

Fig. 4.8 - PV Output Circuit Equipment Ground Terminal

Final Steps



Verify the proper polarity of each conductor. Polarity reversal can lead to dangerous conditions capable of harming personnel and damaging equipment.



Check the Combiner for tools and debris; ensure that the unit is clean and orderly.

- ✓ Return the fuses to the fuseholders, but ***do not close the fuse into the fuseholder***. That will be accomplished during system commissioning and start-up.
- ✓ Verify that all connections meet the requirements of this User’s Manual.
- ✓ Secure the CR1500-xxP-yyF-zzzS Combiner cover, ensuring that both ¼-turn fasteners are secured.
- ✓ Consult the startup and commissioning procedures for the associated XGI 1500 inverter before energizing.

5. OPERATION



Do not operate the disconnect handle switch with the Combiner Box door open.

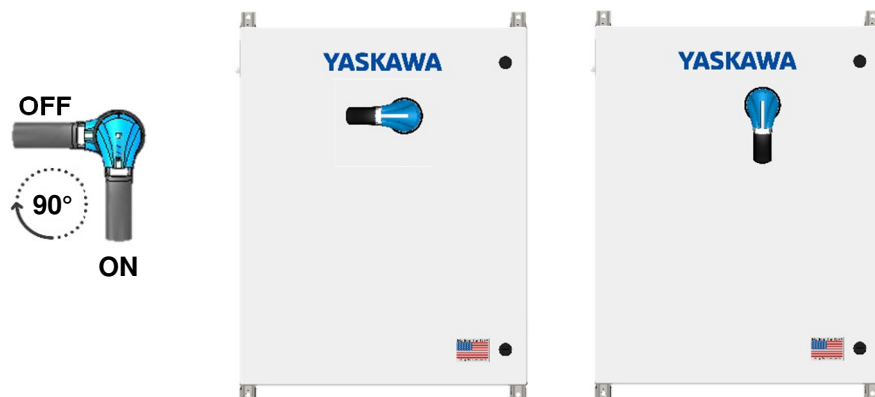

Figure 5.1 – Switch Handle Positions for OFF (left) and ON (right)

The CR1500-xxP-yyF-zzzS Combiner contains a user-operable disconnect switch. When this disconnect switch handle is in the OFF position, the circuit is open between the ungrounded PV Source Circuit conductors and the ungrounded PV Output Circuit conductor(s). The disconnect handle can be locked in the off position with user supplied safety locks. The plastic tab on the face of the disconnect handle can be lifted to reveal the locking provisions.

When the disconnect switch is in the ON position, the PV Source Circuit is closed between the ungrounded PV Source Circuit conductors and the ungrounded PV Output Circuit conductors.

The disconnect switch is rated for 250A in CR1500-xxP-yyF-250S, and 400A in CR1500-xxP-yyF-400S. The switch is fully load-break rated and can be safely operated under normal operating conditions when installation is per this User's Manual and all warnings and ratings are observed.

- ⇒ All Disconnect Switches must be OFF before working on the Combiner.
- ⇒ See also the User's Manual for the **XGI 1500 Inverter**.

6. WARRANTY & RMA INSTRUCTIONS

For warranty information, please visit: <http://solectria.com/support/documentation/warranty-information/grid-tied-inverter-warranty-letter/>

7. APPENDICES

Appendix A – Contact Information

Yaskawa Solectria Solar
360 Merrimack Street
Building 9, Suite 221
Lawrence, MA 01843 USA
Tel: 978.683.9700
Fax: 978.683.9702

Sales/General Info: inverters@solectria.com
Customer Support: 978-683-9700 x2
Website: www.solectria.com

Certificate

Certificate no.

US 72406819 0001

License Holder:

Solectria Renewables LLC
360 Merrimack Street, Bldg. 9, 2nd Fl
Lawrence MA 01843
USA

Manufacturing Plant:

Yaskawa America, Inc.
2 World Packaging Circle
Franklin WI 53132
USA

Report Number: US221PG2 003**Client Reference:** Thomas Shanahan**Certification acc. to:** UL 1741:2021**Product Information****Certified Product:** Remote Combiner Box and PV Combiner Box

Model Designation: 1) CR1500-x-yz; 2) CR1500-xP-yS; 3) CR1500-xP-vS-400
(x= 16, 20, 24, 26, 28;
y= 15, 20, 25, 30, 32;
z= S, W, SW, blank;
v= 20, 25, 30, 32);
4) CR1500-mP-vF-400S; 5) CR1500-mP-vF-250S
(m= 16, 20, 24, 28; v=20, 25, 30, 32)

Technical Data:

Rated Voltage: DC 1500V max.

Rated Current: 1),2),5) DC 200A max.
3),4) DC 320A max.

Protection Class: I

Ambient Temperature Rating: -40 to 60°C

Enclosure Type: Type 4

Special Remarks: To be installed according to licensee's
installation instructions. When there is
28 input positions in model 5), fuse
rating is 20A or 25A only.
Replace Certificate US72226076.

Remarks:**Appendix:** 1, 1-17**Date of issue:**2024-10-23
(yr/mo/day)

TUV Rheinland of North America, Inc.

400 Beaver Brook Rd, Boxborough, MA 01719
Tel +1 (978) 266 9500, Fax +1 (978) 266-9992

www.tuv.com

The TÜVRheinland logo, consisting of a stylized blue triangle with a white wave-like shape inside, followed by the text "TÜVRheinland" in blue with a registered trademark symbol.